

KVL1143-EN-01

KVL-RFID01-02

IDENTIFICATION DEVICE WITH ETHERNET NETWORK

USER MANUAL

KVL-RFID01-02

USER MANUAL

Notice

The following conventions are used to indicate and classify precautions in this manual. Always heed the information provided with them. Failure to heed precautions can result in injury to people or damage to property.

**DANGER**

Indicates an imminently hazardous situation which, if not avoided, will result in death or serious injury. Additionally, there may be severe property damage.

**WARNING**

Indicates a potentially hazardous situation which, if not avoided, could result in death or serious injury. Additionally, there may be severe property damage.

**CAUTION**

Indicates a potentially hazardous situation which, if not avoided, may result in minor or moderate injury, or property damage.

Trademarks

Windows is a registered trademark of Microsoft Corporation in the United States and other countries.

The other brand and product names are trademarks or registered trademarks of their respective owners.

Introduction

We design and manufacture our devices with the feedback from the enterprises of the industry and their specific needs in mind. Our pokayoke systems elaborated this way are robust and due to the sophisticated solutions applied in them, they provide a long maintenance-free lifecycle.

These devices are recommended for those firms where one of the following problems has emerged and would like to develop a solution:

- Frequently occurring errors in production processes;
- Products must be called back due to installing parts of wrong type;
- High scrap-costs caused by selecting wrong part;
- Workers often forget to tighten the screws fixing the part;
- Workers forget to install one or more parts and this mistake is noticed too late;

The pokayoke systems of KVL COMP aid the effective troubleshooting of these errors.

© KVL COMP, 2010

All rights reserved. It is forbidden to reproduce or store this document or part of it in any data-retrieval system or transfer it in any form, in any way (mechanically, electronically, photocopying, recording or with any other technique) without prior written permission from KVL COMP.

We do not take patent responsibility for the information disclosed here. Also, as KVL COMP is constantly striving to improve its high quality products, the information, included in this guide can change without notice. During the creation of this guide we try to be as accurate, as possible, but KVL COMP does not take responsibility for the possible errors or omissions. Also, KVL COMP does not take any responsibility for the possible damages resulting from using this guide.

CONTENTS

I. About this Manual.....	1
II. Related guides.....	1
III. Publication history	1
IV. Warranty and Limitations of Liability	2
V. Application considerations	2
VI. Disclaimers.....	3
VII. Precautions.....	3
CHAPTER 1	5
OVERVIEW	5
1-1 Short introduction of pokayoke systems.....	5
1-2 The location of the identification device in the pokayoke system.....	5
CHAPTER 2	6
TECHNICAL DATA	6
2-1 Dimensions	6
2-2 Electrical data	7
2-3 Ethernet network	7
CHAPTER 3	8
INSTALLATION AND WIRING.....	8
3-1 Installing the controller at the workplace	8
3-2 Connecting to mains and Ethernet network	9
CHAPTER 4	10
SETUP AND OPERATION	10
4-1 Switching on the controller	10
4-2 Controls	10
4-3 Devices attached to the controller	11
4-3-1 WIRELESS BARCODE READER	11
4-3-2 BARCODE READER.....	12
4-3-3 MOBY-U RFID antenna.....	12
4-4 Operation.....	13
4-4-1 with rfid antenna	13
4-4-2 Without RFID antenna	13
4-4-3 RFID device with antenna and spare part checking function (TVP).....	14
4-4-4 RFID device without antenna with spare part cheking function (TVP).....	14
4-4-5 RFID device without antenna only with spare part checking function.....	15
4-5 Light and tone signals.....	15
4-6 Daily checks before work.....	16

Read and Understand this Manual!

Please read and understand this manual before using the product. Please consult your KVL COMP representative if you have any questions or comments.

I. ABOUT THIS MANUAL

This guide explains the installation and operation of the product. Before installing and using the product read this guide carefully and be sure to understand its contents. Also read and follow the safety information described in the next chapter. The chapter titled **Precautions** contains general safety instructions of using the product and the related devices.

Chapter 1: Introduces the product and its structural units

Chapter 2: Explains the structure of the product.

Chapter 3: Explains the installation of the product, the wiring of the power supply and the I/O lines and also the functional testing of the product.

Chapter 4: Explains the setup and operation of the product.

II. RELATED GUIDES

The following guides give information on the related devices. You can find the necessary information in the following documents.

Cat.No.	Title of Publication	Description
KVL1144	IDENTIFICATION DEVICE WITH ETHERNET NETWORK	MAINTENANCE MANUAL
KVL1001	POWER CABLE	DATASHEET
KVL1002	ETHERNET PATCH CABLE	DATASHEET

III. PUBLICATION HISTORY

The number of the publication is also indicated on the cover of the publication.

NUMBER OF PUBLICATION: KVL1143-EN-01

Date of Publication	No. of Publication	Chapter	Revised content
12. 2010.	KVL1143-EN-01		1st edition

IV. WARRANTY AND LIMITATIONS OF LIABILITY

WARRANTY

KVL COMP's exclusive warranty is that the products are free from defects in materials and workmanship for a period of one year (or other period if specified) from date of sale by KVL COMP.

LIMITATIONS OF LIABILITY

KVL COMP shall not be responsible for special, indirect, or consequential damages, loss of profits or commercial loss in any way connected with the products, whether such claim is based on contract, warranty, negligence, or strict liability.

In no event shall the responsibility of KVL COMP for any act exceed the individual price of the product on which liability is asserted.

In no event shall KVL COMP be responsible for warranty, repair, or other claims regarding the products unless KVL COMP's analysis confirms that the products were properly handled, stored, installed, and maintained and not subject to contamination, abuse, misuse, or inappropriate modification or repair.

V. APPLICATION CONSIDERATIONS

SUITABILITY FOR USE

The following are some examples of applications for which particular attention must be given. This is not intended to be an exhaustive list of all possible uses of the products, nor is it intended to imply that the uses listed may be suitable for the products:

- Outdoor use, uses involving potential chemical contamination or electrical interference, or conditions or uses not described in this manual.
- Installations subject to separate industry or government regulations.
- Systems, machines, and equipment that could present a risk to life or property.

Please know and observe all prohibitions of use applicable to the products.

PROGRAMMABLE PRODUCTS

KVL COMP shall not be responsible for the user's programming of a programmable product, or any consequence thereof.

VI. DISCLAIMERS

CHANGE IN SPECIFICATIONS

Product specifications and accessories may be changed at any time based on improvements and other reasons.

It is our practice to change model numbers when published ratings or features are changed, or when significant construction changes are made. However, some specifications of the products may be changed without any notice. When in doubt, special model numbers may be assigned to fix or establish key specifications for your application on your request. Please consult with your KVL COMP representative at any time to confirm actual specifications of purchased products.

DIMENSIONS AND WEIGHTS

Dimensions and weights are nominal and are not to be used for manufacturing purposes, even when tolerances are shown.

PERFORMANCE DATA

Performance data given in this manual is provided as a guide for the user in determining suitability and does not constitute a warranty. It may represent the result of KVL COMP's test conditions, and the users must correlate it to actual application requirements.

ERRORS AND OMISSIONS

The information in this manual has been carefully checked and is believed to be accurate; however, no responsibility is assumed for clerical, typographical, or proofreading errors, or omissions.

VII. PRECAUTIONS

This section provides general precautions for using the related devices.

The information contained in this section is important for the safe and reliable application of product. You must read this section and understand the information contained before attempting to set up or operate a product.

INTENDED AUDIENCE

This manual is intended for the following personnel:

- workers trained to the specific task, working on the assembly stations and on the assembly line, operating the device, work group leaders;
- professionals responsible for the installation, setup and maintenance of the device.

GENERAL PRECAUTIONS

The user must operate the product according to the performance specifications described in the operation manuals.

Before using the product under conditions which are not described in the manual or applying the product to other systems, machines, and equipment that may have a serious influence on lives and property if used improperly, consult your KVL COMP representative.

Make sure that the ratings and performance characteristics of the product are sufficient for the systems, machines, and equipment.

This manual provides information for setup and operating the product. Be sure to read this manual before attempting to use the product and keep this manual close at hand for reference during operation.



WARNING

It is extremely important that a product be used for the specified purpose and under the specified conditions, especially in applications that can directly or indirectly affect human life. You must consult with your KVL COMP representative before applying a product to the above-mentioned applications.

SAFETY PRECAUTIONS



CAUTION

When power is ON or has just been turned OFF, do not touch the power supply, I/O terminals, or the surrounding areas.



CAUTION

Secure the AC power supply line to the terminal block with a 0.5N·m of torque. Loosening the screw may result in a fire or malfunction.

APPLICATION PRECAUTIONS



CAUTION

On modifying the program, always ensure that switching to MONITOR or RUN mode does not lead to unexpected effects.

CHAPTER 1

OVERVIEW

This guide explains the installation, wiring and setup of the KVL-RFID01-02 Ethernet network controller and describes its operation. The installation, wiring and setup of the product must be accomplished by experienced professionals.

The description of operation provides information for the workers working with the pokayoke system.

1-1 SHORT INTRODUCTION OF POKAYOKE SYSTEMS

The meaning of the Japanese words Poka-Yoke in free translation:

- Poka: random, unintentional error, mistake, fault
- Yoke: elimination, prevention

Meaning: mistake-free, error-free work, workstation, technology, process development, in order to avoid human errors. The aim of pokayoke is the full-scale prevention of product defects, waste avoidance, minimization of quality control costs, to provide error-free working conditions and work.

To sum up, pokayoke is a system that assists manufacturing and assembling, that helps and – simultaneously – controls the workers. Using pokayoke effectively improves waste avoidance.

The KVL-RFID 01-02 is part of the Ethernet network based pokayoke system developed by KVL COMP.

1-2 THE LOCATION OF THE IDENTIFICATION DEVICE IN THE POKAYOKE SYSTEM

The identification device is identifying the bodywork/spare parts as follows:

1. Bodywork identification with RFID reader (MOBY-U) and wired bar code reader (nostrategy).
2. Bodywork identification with wired bar code reader (nostrategy).
3. Spare part identification (TVP) with wireless and wired bar code reader (nostrategy).
4. Bodywork identification with RFID reader (MOBY-U) and wired bar code reader (nostrategy) spare part identification (TVP) with wired and wireless bar code reader (nostrategy).

The occurring errors can be acknowledged with key switches (in the VW groups case E7 key switches). The controllers operation and the error messages are displayed on the light column. The light column gives sound and light (green/yellow/red) signals.

CHAPTER 2

TECHNICAL DATA

2-1 DIMENSIONS

The KVL-RFID01-02 controller is installed in a plastic case.

Dimensions of the controller box: 250*160*150 mm

Colour of the controller box: Grey RAL 7032

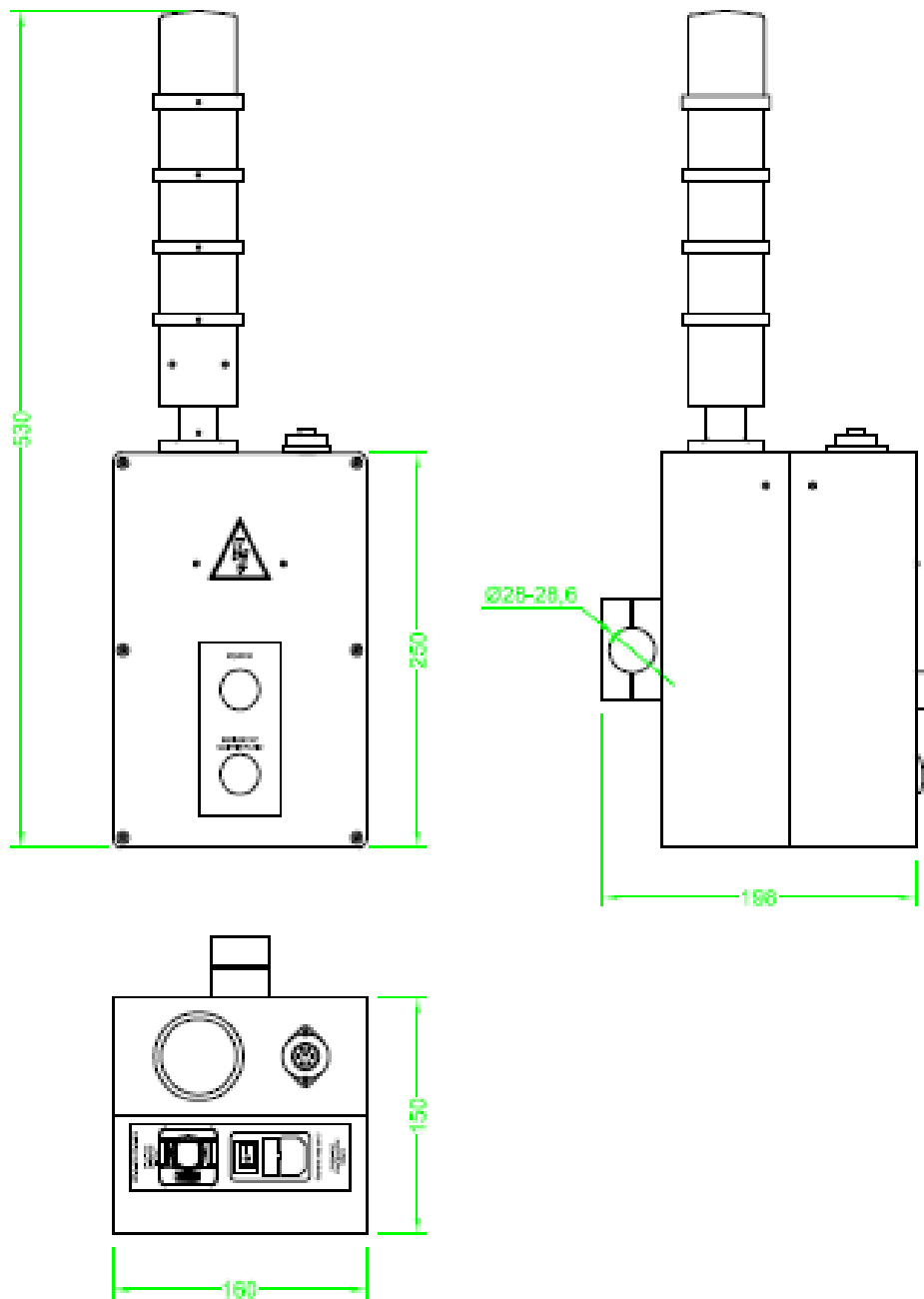

2-2 ELECTRICAL DATA

Supply voltage:	230 V AC 50 Hz
Current drain:	2 A
Operating range:	100 ... 240 V 48 ... 62 Hz
Operating temperature:	5 ... 40°C
Operating humidity:	20 ... 90% RH non-condensing
Storage temperature:	-20 ... 70°C
Storage humidity:	10 ... 95% RH non-condensing
Mains circuit connection:	IEC standard connector, with fuse and switch
Fuse:	5*20 glass-tube; 230 V 10 A SLOW
Recommended mains connector cable:	KVL-POW



2-3 ETHERNET NETWORK

The controller can be connected to standard 10/100 Ethernet network.

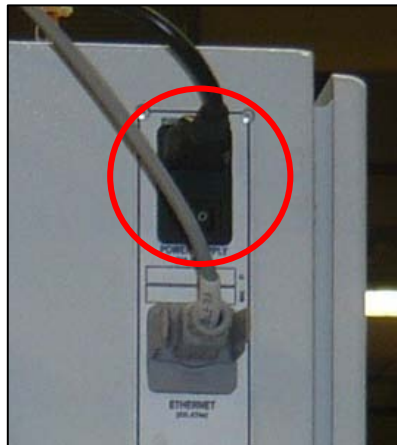

The industrial Ethernet socket is of type VARIOSUB-RJ45.
The recommended Ethernet cable is of type KVL-ETN.

CHAPTER 3

INSTALLATION AND WIRING

3-1 INSTALLING THE CONTROLLER AT THE WORKPLACE

The control box will be installed on TRILOGIQ shelf system.

The plastic clamps, what is necessary for the installation, is fixed to the back cover of the control box (Accessory).



KVL-RFID01-02

3-2 CONNECTING TO MAINS AND ETHERNET NETWORK

The sockets are located on the back of the controller.

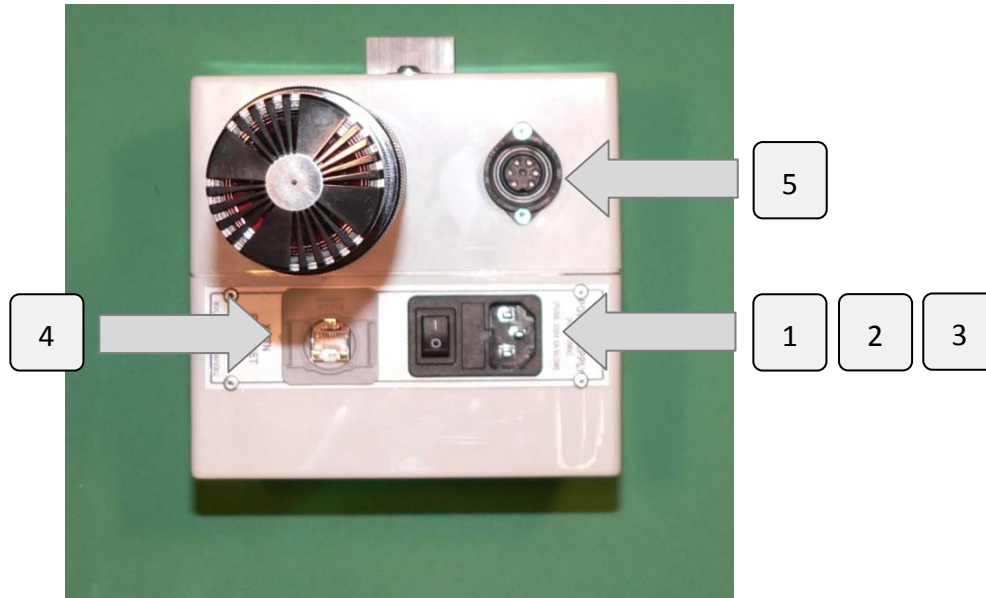

1. Mains (230 V AC) socket;
2. Glass tube fuse: 5*20 glass tube; 230 V 2A SLOW;
3. On/off switch;
4. Ethernet socket;
5. MOBY-U socket.

For connecting to the mains circuit we recommend the type KVL-POW cable. Ensure that the controller is switched off when you connect the cable.



WARNING Risk of electric shock when using wrong or damaged mains connector cable!



WARNING Risk of fire and human injury when using damaged, repaired fuses or fuses not of the appropriate type!

For connecting to the Ethernet network we recommend the type KVL-ETN cable.

CHAPTER 4 SETUP AND OPERATION

4-1 SWITCHING ON THE CONTROLLER

The device is turned on with the switch located next to the power supply connector.



After switching off the device, always wait at least 5 seconds before switching it on again!

4-2 CONTROLS

On the Pick-to-light controllers front cover, a white light is installed what shows if the power is on.

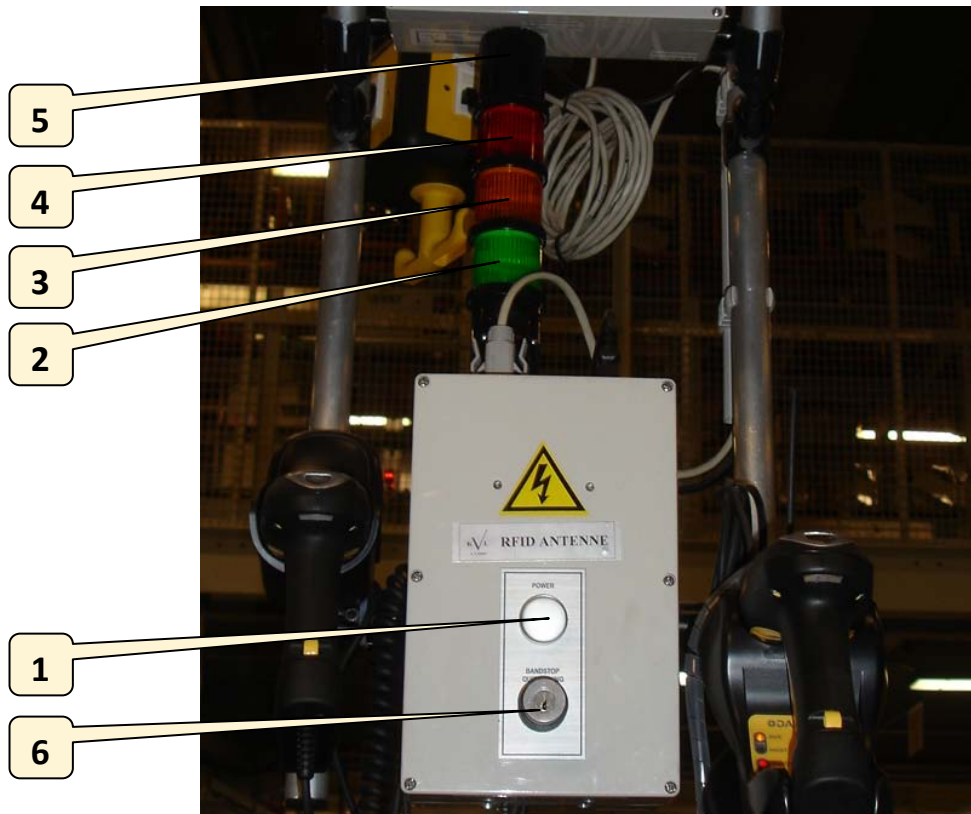

1. **POWER ON INDICATOR LIGHT:** If the controller is on, the „POWER” labeled light glows.
2. **SIGNAL POST, GREEN LAMP:** Glows, if the worker successfully picked up all the necessary part.
3. **SIGNAL POST, YELLOW LAMP:** In case of server error it glows (with the red [4] one)
4. **SIGNAL POST, RED LAMP:** In case of error it glows.
5. **SIGNAL POST, AUDIBLE SIGNAL:** In case of controlling error and wrong spare part picking-up audible signal can be heard.
6. **ACKNOWLEDGING ERRORS:** Errors are acknowledged using the E7 key switch.

4-3 DEVICES ATTACHED TO THE CONTROLLER

4-3-1 WIRELESS BARCODE READER

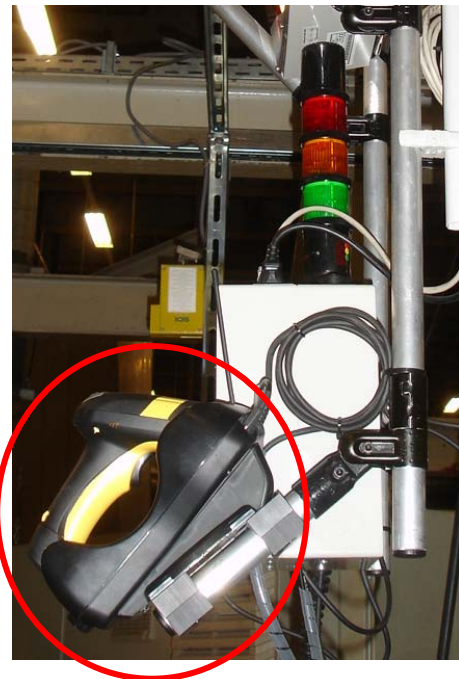

The role of the wireless bar code reader:

- In RFID identification mode if there is a MOBY-U reader failure the sequence number-kennummer scanning from the worksheet (nostrategy).
- In RFID identification mode when there's no data in the tag: the sequence number-kennummer scanning from the worksheet (nostrategy).
- In spare part identification mode it reads the spare part numbers.

4-3-2 BARCODE READER



In case the cordless barcode reader is malfunctioning, use this device to scan barcodes from worksheets. (Nostrategy)

4-3-3 MOBY-U RFID ANTENNA



Performs the data scanning from the body part.

4-4 OPERATION

The identification device is identifying the bodywork/spare parts as follows:

1. Bodywork identification with RFID reader (MOBY-U) and wired bar code reader (nostrategy).
2. Bodywork identification with wired bar code reader (nostrategy).
3. Spare part identification (TVP) with wireless and wired bar code reader (nostrategy).
4. Bodywork identification with RFID reader (MOBY-U) and wired bar code reader (nostrategy) spare part identification (TVP) with wired and wireless bar code reader (nostrategy).

The occurring errors can be acknowledged with key switches (in the VW groups case E7 key switches). The controllers operation and the error messages are displayed on the light column. The light column gives sound and light (green/yellow/red) signals.

4-4-1 WITH RFID ANTENNA

The installed RFID devices primary role is to identify the incoming car.

According to the message from the server it starts to scan the data from the tag. After the successful scanning it sends the data to the server. The server based on the data makes a search in the database. After the successful search the server indicates a message that it found the car in the database. After this the RFID turns on the green light on the light column and sends a „Work done“ message to the server. In case that the RFID is not ready to work according to INI2 and INI3 messages it gives sound and light signals showing the actual state of the work to the employee. In case that the RFID can not scan the data from the tag the device automatically indicates to the operator, that he has to identify the incoming car with a bar code reader for the interest of further work. The scanned bar code data the RFID sends to the server. According to this data the server searches for the car, it sends a successful or unsuccessful search message to the RFID. Based on the content of the message the RFID indicates a „work done“ or „the bar code was not appropriate“ message to the operator (the server did not find this car in the database).

4-4-2 WITHOUT RFID ANTENNA

The RFID according to the message from the server decides what working mode he has to operate on further. In that case that the server sends that information, that the car is already identified from the main line data it sends a work done sign back to the server. If the server does not get the information about the car from the main line, the RFID indicates to the operator that he has to identify the car with the bar code reader. The identification process described above.

4-4-3 RFID DEVICE WITH ANTENNA AND SPARE PART CHECKING FUNCTION (TVP)

The RFID devices primary role is to identify the car arriving to the workplace. After this to check if the spare parts are the correct ones according to the data what he received from the server. The RFID according to the message from the server starts to scan the data from the tag. After the successful scanning it sends the scanned data to the server. The server makes a search in the database according to this data. After the successful search it indicates in a message that he found the car in the database. The server sends a message to the device about the needed identification numbers of the spare parts what needs to be built in. The device compares the spare part numbers to the saved data and if it finds a match it indicates a "successful reading" message to the operator. In case that the read in spare part number is not between the saved data it indicates as an "incorrect reading. When the operator built in all the spare parts what he checked with the bar code reader, the device sends a "work done" message to the server and the green light glows. If it is more than one spare part from the same kind what needs to be built in, the operator needs to scan the barcode from the spare part as many times as many spare parts are needed. In case that the RFID is not ready to work according to INI2 and INI3 messages it gives sound and light signals showing the actual state of the work to the employee.

4-4-4 RFID DEVICE WITHOUT ANTENNA WITH SPARE PART CHECKING FUNCTION (TVP)

The RFID devices primary role is to check the spare part numbers what has to be built in and to identify the car arriving to the workplace. The RFID according to the message what he receives from the server decides what operating mode he has to work on further. In that case when the server sends a message that the incoming car is already identified, it is waiting for the data needed for the further operation. After receiving the data it indicates to the operator to scan the barcode number with the barcode reader what was built in.

If the server sends a message to the device that there is no information about the incoming car, then the device indicates to the operator that the identification of the car is necessary for further work. The operator with the barcode reader scans the barcode of the bodywork and the device sends it to the server. The server makes a search in the database, if it finds it then it informs the device in a message about the successful hit found. After the device received the data, it indicates to the operator, that spare part identification is necessary. When the operator scanned all the spare part numbers with the barcode reader the device indicates that the work is done and sends a "work done" message to the server.

In case that the RFID is not ready to work according to INI2 and INI3 messages it gives sound and light signals showing the actual state of the work to the employee.

4-4-5 RFID DEVICE WITHOUT ANTENNA ONLY WITH SPARE PART CHECKING FUNCTION

The RFID devices only role is to check the spare part numbers what has to be built in. After the INI1 signal received from the server, the device is waiting for the data what is necessary for the work. If the device received this data it indicates to the operator that spare part identification is needed.

When the operator scanned all the spare part numbers with the barcode reader the device indicates that the work is done and sends a “work done” message to the server.

In case that the RFID is not ready to work according to INI2 and INI3 messages it gives sound and light signals showing the actual state of the work to the employee.

4-5 LIGHT AND TONE SIGNALS

During operation the RFID controller gives audible and visual warnings for the operator, informs him about the operating regime and possible errors.

	RED	YELLOW	GREEN	HORN
Base position	OFF	OFF	OFF	OFF
Server connection error	OFF	ON	OFF	3X
RFID reading in progress	OFF	BLINK	BLINK	OFF
RFID or barcode reading result OK	OFF	OFF	ON	OFF
RFID reading error	ON	BLINK	OFF	2X
Barcode reading is necessary	BLINK	OFF	BLINK	1X
Barcode processing in progress	OFF	OFF	BLINK	OFF
Barcode error [TVP]	ON	OFF	OFF	2X

4-6 DAILY CHECKS BEFORE WORK

Daily routine check of control cabinet:

Cabinet door is closed:

- Proper ventilation and protection of the inner parts are only provided with closed cabinet door!
- Touching the inner parts can cause electric shock.
- Via the open door dust can penetrate the cabinet. The accumulating dust decreases cooling efficiency and leads to a higher probability of failure.



WARNING In the following cases switch off the controlbox, disconnect network cable and call a service technician immediately:

- The network cable or its connector is damaged or worn.
- Liquids penetrated the controlbox.
- The controlbox was exposed to rain or other forms of water.
- The controlbox fell or its case is damaged.
- The operation of the controlbox is unstable or the controlbox is malfunctioning.
- The controlbox emits unusual noise, smoke or unpleasant smell.

KVL COMP s.r.o.

Komenského 35, 94301 Štúrovo
SLOVAKIA

Tel.: 00-36-33-501-616

Fax: 00-36-33-501-615

www.kvlcomp.eu

info@kvlcomp.eu

KVL COMP Vezérléstechnikai Kft.

H-2500 Esztergom, Nagy Sándor József utca 3.
HUNGARY

Tel.: 00-36-33-501-616

Fax: 00-36-33-501-615

www.kvlcomp.eu

info@kvlcomp.eu

